

OPUS VIEW SMARTLOCK™ BALUSTRADE SYSTEM SIDE FIX

FOR RESIDENTIAL & COMMERCIAL OCCUPANCY A, A OTHER, C3, C1/C2, D, B & E OF TABLE 3.3 AS/NZS 1170.1

NOTES:

1) This proprietary balustrade system complies with New Zealand Building Code Clause B1 Structure, B1/AS1 Amendment 15, B1/VM1, F2 Hazardous Building Materials and F4 Safety From Falling Third Addition, subject to:

- all products meeting the required performance specification
- site installation carried out in accordance with intent of this drawing and to be installed by a certified glass balustrade practitioner

For residential & commercial occupancy A, A Other, C3, C1/C2, D, B & E of Table 3.3 AS/NZS 1170.1

2) Design of support structure is the responsibility of others

3) A handrail of 32-50mm diameter is required for stairs and ramps exceeding 1:20 slope. Refer NZBC D1/AS1

4) Safety glass Options according to 22.4.3 of NZS 4223.3:2016 are:

- 12mm Toughened Glass with interlinking Rail
- 13.52mm SentryGlas
- 15mm Toughened Glass with interlinking Rail
- 15.2mm Laminated Glass
- 17.2mm Laminated Glass
- 17.52mm SentryGlas
- 21.52mm SentryGlas

NOTE: All 12mm & 15mm glass balustrade to be provided with an interlinking rail as per NZBC NZS4223.3 and F4

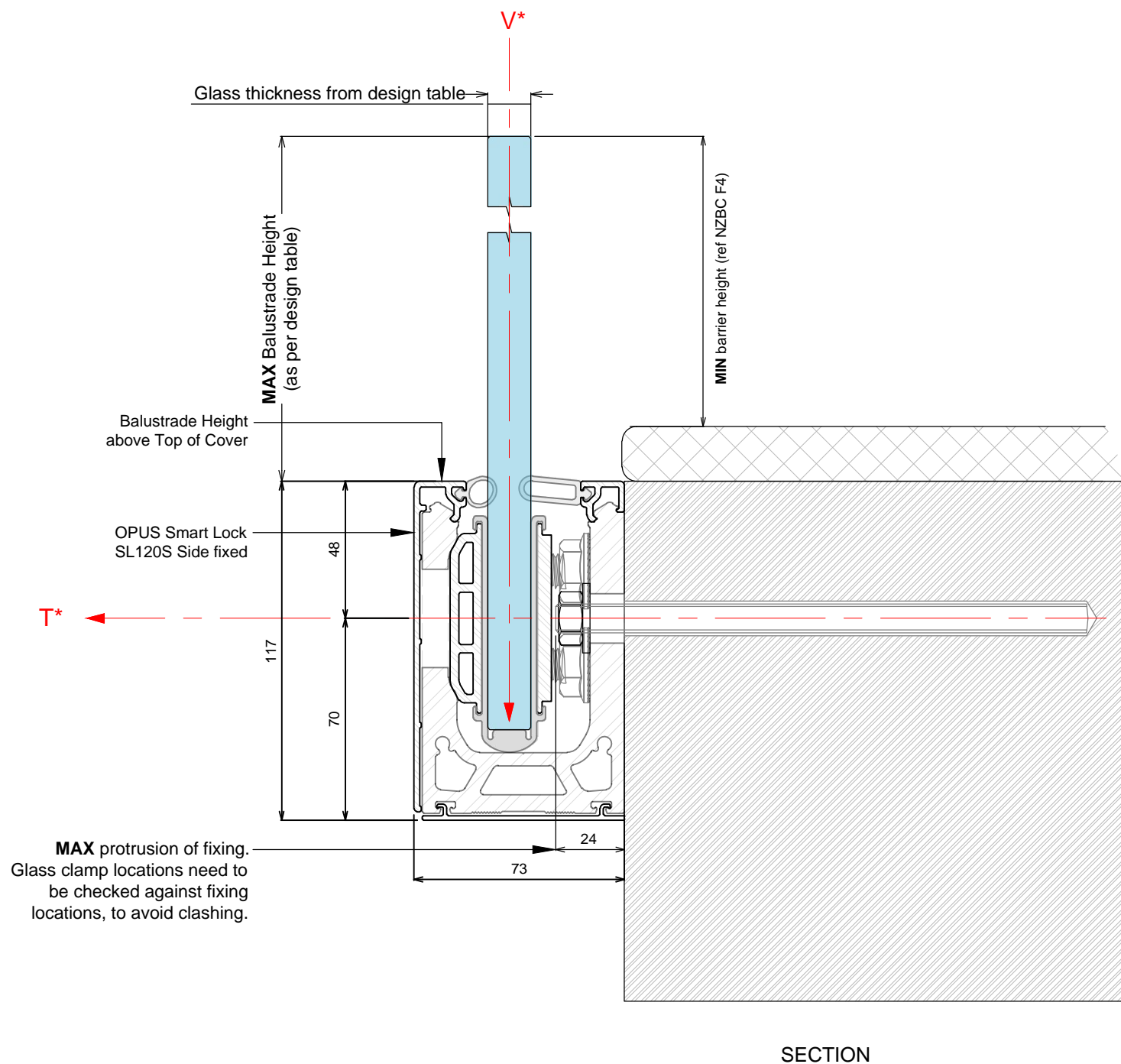

OPUS VIEW SMARTLOCK™ BALUSTRADE SYSTEM SIDE FIX DESIGN TABLES

FOR RESIDENTIAL & COMMERCIAL OCCUPANCY A, A OTHER, C3, C1/C2, D, B & E OF TABLE 3.3 AS/NZS 1170.1

Allowable Heights for Side Fix Balustrade

Glass Thickness, Type	Wind Zone	Height, mm (Max Balustrade)	Fix attach centres, mm
-----------------------	-----------	-----------------------------	------------------------

Residential Occupancy A, A Other and C3 only

12mm Toughened	High	1300	400
	Very High	1200	200
	Extra High	1050	200
13.52mm SentryGlas	High	1300	400
	Very High	1200	200
	Extra High	1050	200
15.2mm Laminated	High	1300	400
	Very High	1200	200
	Extra High	1050	200

Commercial Occupancy B, E and C3 only

15mm Toughened	High	1500	200
	Very High	1300	200
	Extra High	1200	200
17.2mm Laminated	High	1500	200
	Very High	1300	200
	Extra High	1200	200
17.52mm SentryGlas	High	1500	200
	Very High	1300	200
	Extra High	1200	200
21.52mm SentryGlas -Timber not suitable	High	1800	200
	Very High	1600	200
	Extra High	1400	200

Commercial Occupancy C1/C2 and D only

21.52mm SentryGlas -Timber not suitable	Extra High	1100	200
--	------------	------	-----

For SentryGlas, Stiffener Brackets MUST be used

above these Heights or below these Widths

Glass Thickness, Type	Barrier Height, mm (max above Clamp)	Panel Width, mm (minimum)
13.52mm SentryGlas	1200	1700
17.52mm SentryGlas	1300	1200
21.52mm SentryGlas	1300	1100

For Pool Fencing only - Side Fix Only

Wind Zone up to and Including	Heights for Glass, 12mm Toughened	Heights for Glass, 15mm Toughened	Fix attach centres, mm
Medium	1500	1700	200
High	1350	1550	200
Very High	1200	1350	200
Extra High	N/A	1250	200

Layered Glasses, Construction

Laminated Glass Layers & Thickness Orientation

Glass Thickness, Type	Inner Layer of Glass thickness (mm) Deckside	Interlayer of Glass thickness (mm) & Type	Outer Layer of Glass thickness (mm)
15.2	6	1.2 EVA	8
17.2	8	1.2 EVA	8

SentryGlas Layers & Thickness Orientation

Glass Thickness, Type	Inner Layer of Glass thickness (mm) Deckside	Interlayer of Glass thickness (mm) & Type	Outer Layer of Glass thickness (mm)
13.52	6	1.52 SG	6
17.52	8	1.52 SG	8
21.52	10	1.52 SG	10

NOTES:

- 1) For Toughened Glass, Opus Interlinking Rails or Handrails MUST be used. Not for use with Stiffener Brackets.
- 2) For Laminated Glass, Opus Interlinking Rails, Handrails or Stiffener Brackets may be used.
- 3) SentryGlas, Opus Interlinking Rails, Handrails or Stiffener Brackets may be used, but see table.

Design Loads - all Side Fix only

For use by Project Engineers to develop Site Specific designs

SMARTLOCK SIDE SIX ONLY				Design Loads to Substructure (per fixing point)		Wind Pressures (ULS to SLS Factor 0.75)		
Glass Type & Thickness (mm)	Occupancy	Max Balustrade Height (mm)	Fixing Centres (mm)	T* (kN)	V* (kN)	Wind Zones	ULS	SLS
12T, 13.52SG, 15.2L	Residential Occupancy A, A Other & C3	1300	400	12.33	0.5	High	1.69	1.27
		1200	200	10.49	0.47	Very High	2.2	1.65
		1050	200	9.46	0.41	Extra High	2.69	2.02
15T, 17.52SG, 17.2L	Commercial Occupancy A, B, E and C3	1500	200	10.44	0.67	High	1.67	1.25
		1300	200	10.52	0.58	Very High	2.16	1.64
		1200	200	10.6	0.54	Extra High	2.66	2.00
21.52SG	Commercial Occupancy A, B, E and C3	1800	200	11.4	0.99	High	1.74	1.31
		1600	200	12.02	0.88	Very High	2.28	1.71
		1400	200	11.58	0.77	Extra High	2.79	2.09
12T, 15T	Pool Fence Only	1250	200	12.2	0.06	Extra High	2.84	2.13
				13.6	0.48	Extra High	2.65	1.99

Notes:

- 1 - Glass thickness, mm
- Glass type T = Toughened, L = Laminated, SG = SentryGlas

OPUS VIEW SMARTLOCK™ BALUSTRADE SYSTEM SIDE FIX CONCRETE FIXING DETAIL

FOR RESIDENTIAL & COMMERCIAL OCCUPANCY A, A OTHER, C3, C1/C2, D, B & E OF TABLE 3.3 AS/NZS 1170.1

NOTES: Refer to design tables and elevations for post failure requirements. Interlinking rail / clips not shown for clarity.

Maximum Balustrade Heights Up to and including Extra High Wind Zone					
Residential Occupancy A, A other & C3 only		Commercial Occupancy B, E & C3 only		Commercial Occupancy C1/C2 & D	
Glass Thickness, Type	Balustrade Height (max)	Glass Thickness, Type	Balustrade Height (max)	Glass Thickness, Type	Balustrade Height (max)
12 T	1050	15 T	1200	21.52 SG	1100
13.52 SG	1050	17.2 L	1200		
15.2 L	1050	17.52 SG	1200		
		21.52 SG	1400		

General Notes:
 1 - Glass thickness, mm
 Glass type T = Toughened, L = Laminated, SG = SentryGlas
 2 - All measurements mm
 3 - Refer to typical Layouts for Max Panel widths and the use of Top Interlinking Rails (T & L) or Stiffener Brackets (L & SG)

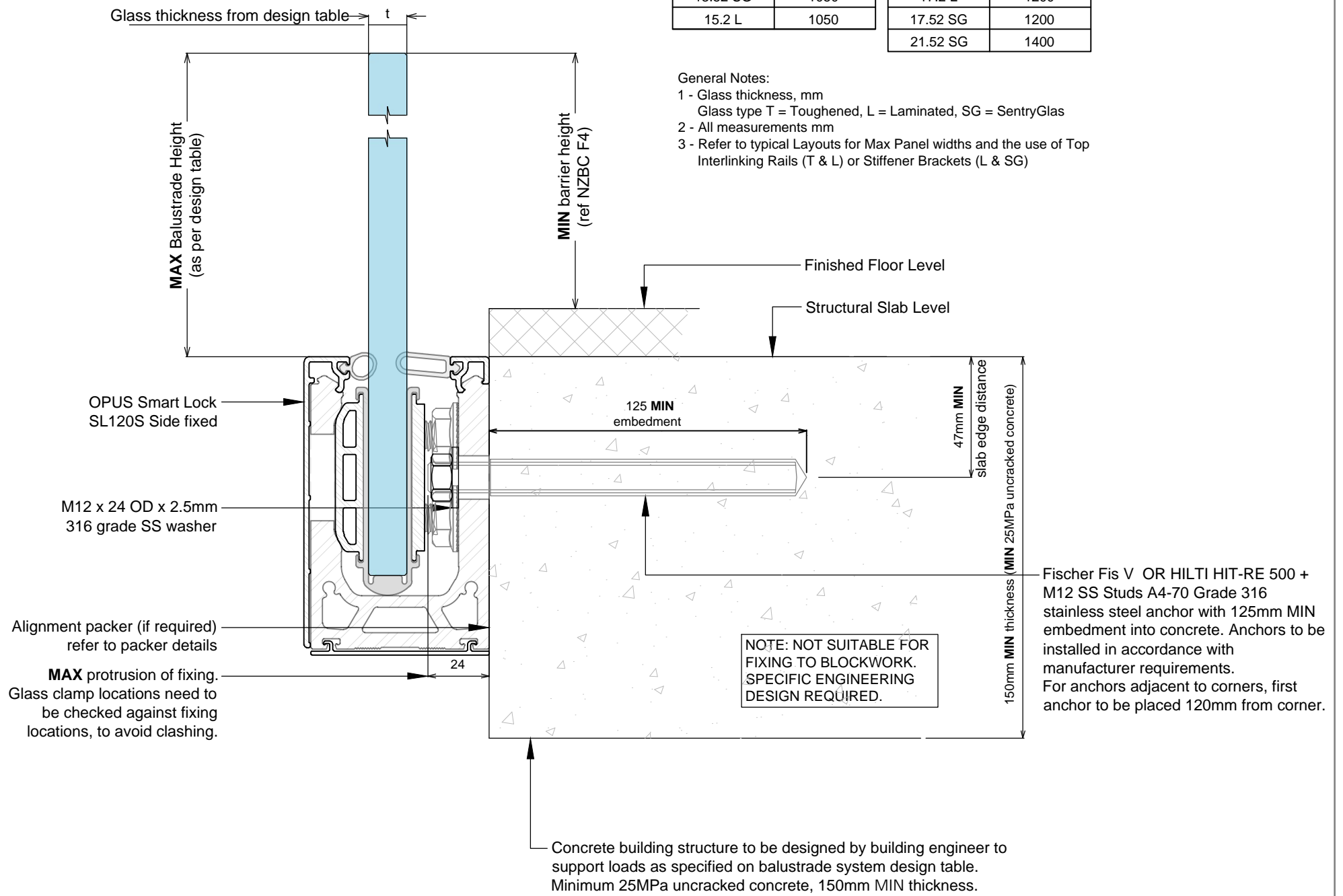

NOTES:

- 1) Capacity of structure is to be of sufficient strength to support loads M* and T* specified on balustrade system design table. Structure capacity to be verified by building engineer prior to fixing balustrade.
- 2) Max loading to comply with AS/NZS 1170.1:2002 Minimum Imposed Actions for Barriers Occupancy, shown at top of drawing, for design in accordance with balustrade system design table.
- 3) No substitution allowed - any variation from the details above and design tables will require specific design.
- 4) Substructure designer to ensure that there is no water runoff from dissimilar metals or treated timber onto barrier components.
- 5) E2 & Drainage responsibility of project engineer, to ensure that channel drainage design is not blocked or prevented to perform as designed.

OPUS VIEW SMARTLOCK™ BALUSTRADE SYSTEM SIDE FIX TIMBER FIXING WITH COACH SCREW DETAIL

FOR RESIDENTIAL & COMMERCIAL OCCUPANCY A, A OTHER, C3, C1/C2, D, B & E OF TABLE 3.3 AS/NZS 1170.1

NOTES: Refer to design tables and elevations for post failure requirements. Interlinking rail / clips not shown for clarity.

Maximum Balustrade Heights Up to and including Extra High Wind Zone			
Residential Occupancy A, A other & C3 only		Commercial Occupancy B, E & C3 only	
Glass Thickness, Type	Balustrade Height (max)	Glass Thickness, Type	Balustrade Height (max)
12 T	1050	15 T	1200
13.52 SG	1050	17.2 L	1200
15.2 L	1050	17.52 SG	1200

General Notes:

- 1 - Glass thickness, mm
Glass type T = Toughened, L = Laminated, SG = SentryGlas
- 2 - All measurements mm
- 3 - Refer to typical Layouts for Max Panel widths and the use of Top Interlinking Rails (T & L) or Stiffener Brackets (L & SG)

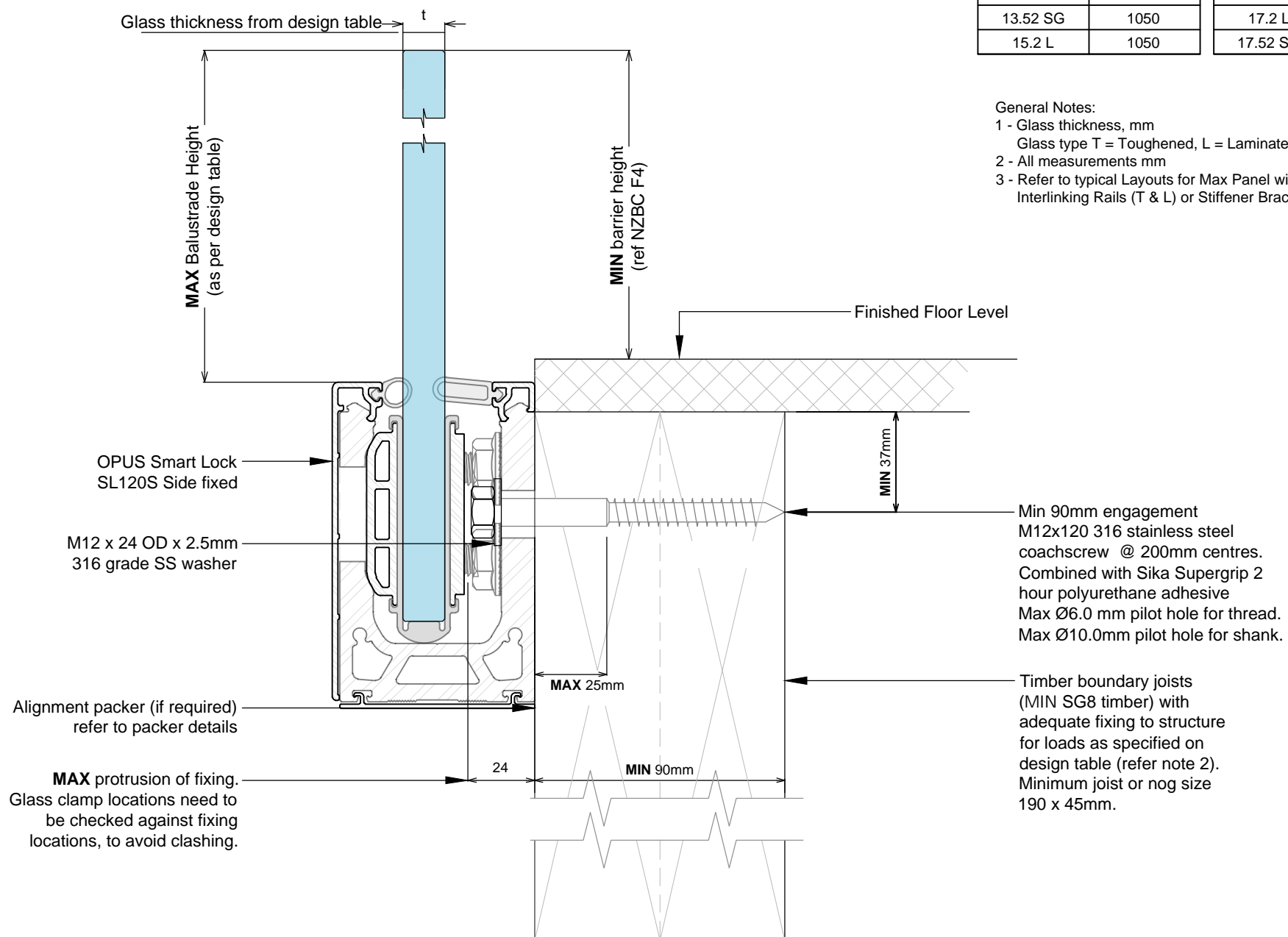

NOTES:

- 1) Capacity of structure is to be of sufficient strength to support loads M* and T* specified on balustrade system design table. Structure capacity to be verified by building engineer where applicable or checked to NZS3604 requirements prior to fixing balustrade.
- 2) Timber decks designed to NZS 3604:2011 guidelines will meet loading requirement, **except for decks including cantilever floor joists where specific design is required.** Substructure only indicate only, Min SG8 Timber.
- 3) Max loading to comply with AS/NZS 1170.1:2002 Minimum Imposed Actions for Barriers Occupancy, shown at top of drawing, for design in accordance with balustrade system design table.
- 4) For fixing to timber substrates, the installer shall ensure that the bolt / coach screw is sufficiently tightened to reduce movement of the bolt head and washer. Care should be taken not to over tighten the fixings that would cause crushing of the timber or compromise the thread leading to anchor pull-out.
- 5) No substitution allowed - any variation from the details above and design tables will require specific design.
- 6) Fixings to timber must be re-tightened 2 months after installation and periodically thereafter to allow for timber shrinkage.
- 7) Substructure designer to ensure that there is no water runoff from dissimilar metals or treated timber onto barrier components.
- 8) E2 & Drainage responsibility of project engineer, to ensure that channel drainage design is not blocked or prevented to perform as designed.

OPUS VIEW SMARTLOCK™ BALUSTRADE SYSTEM SIDE FIX TIMBER FIXING WITH THROUGH BOLT FIXING DETAIL

FOR RESIDENTIAL & COMMERCIAL OCCUPANCY A, A OTHER, C3, C1/C2, D, B & E OF TABLE 3.3 AS/NZS 1170.1

NOTES: Refer to design tables and elevations for post failure requirements. Interlinking rail / clips not shown for clarity.

Maximum Balustrade Heights Up to and including Extra High Wind Zone			
Residential Occupancy A, A other & C3 only		Commercial Occupancy B, E & C3 only	
Glass Thickness, Type	Balustrade Height (max)	Glass Thickness, Type	Balustrade Height (max)
12 T	1050	15 T	1200
13.52 SG	1050	17.2 L	1200
15.2 L	1050	17.52 SG	1200

General Notes:

- 1 - Glass thickness, mm
Glass type T = Toughened, L = Laminated, SG = SentryGlas
- 2 - All measurements mm
- 3 - Refer to typical Layouts for Max Panel widths and the use of Top Interlinking Rails (T & L) or Stiffener Brackets (L & SG)

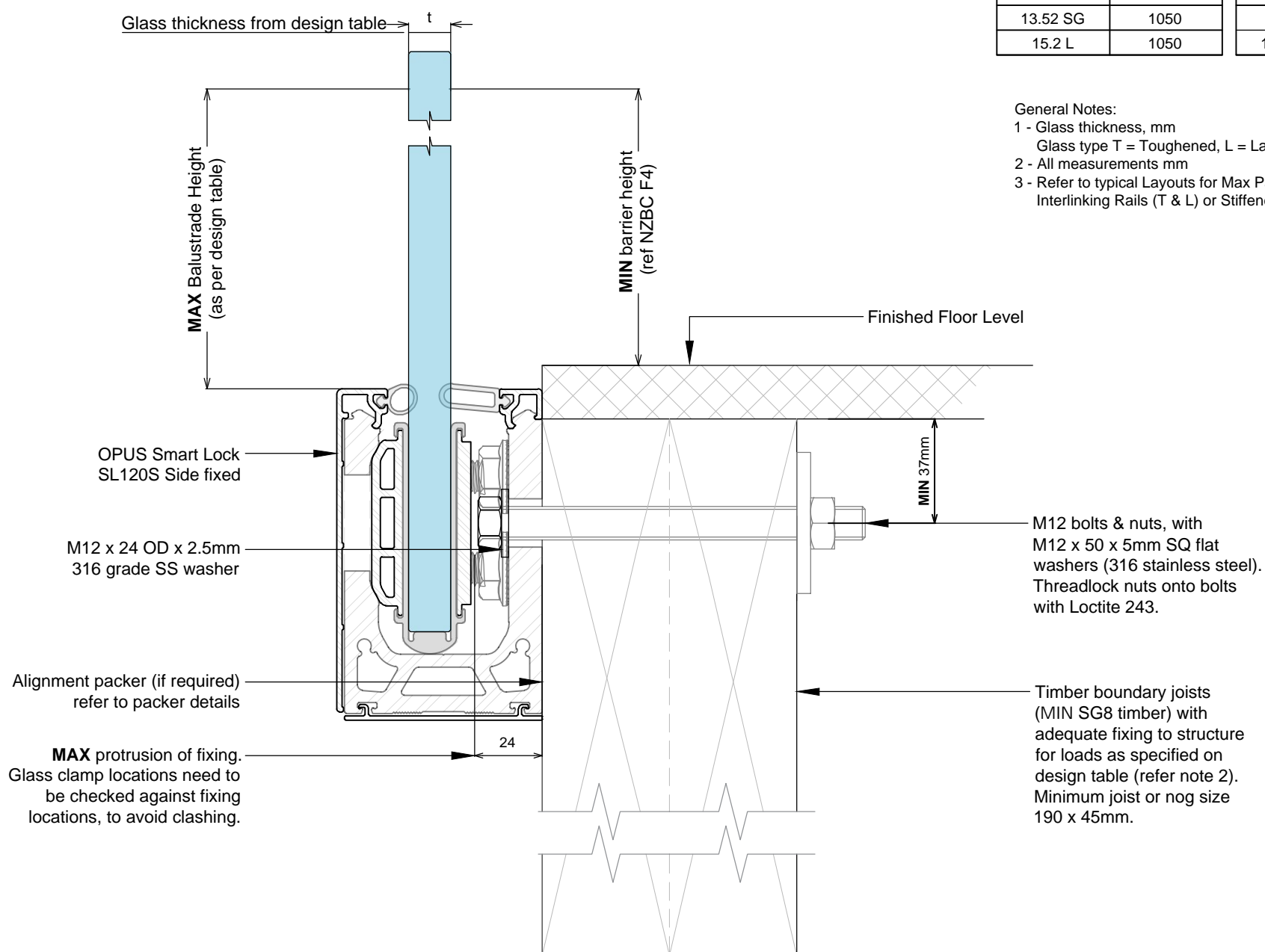

NOTES:

- 1) Capacity of structure is to be of sufficient strength to support loads M* and T* specified on balustrade system design table. Structure capacity to be verified by building engineer where applicable or checked to NZS3604 requirements prior to fixing balustrade.
- 2) Timber decks designed to NZS 3604:2011 guidelines will meet loading requirement, **except for decks including cantilever floor joists where specific design is required.**
- 3) Max loading to comply with AS/NZS 1170.1:2002 Minimum Imposed Actions for Barriers Occupancy, shown at top of drawing, for design in accordance with balustrade system design table.
- 4) For fixing to timber substrates, the installer shall ensure that the bolt / coach screw is sufficiently tightened to reduce movement of the bolt head and washer. Care should be taken not to over tighten the fixings that would cause crushing of the timber or compromise the thread leading to anchor pull-out.
- 5) No substitution allowed - any variation from the details above and design tables will require specific design.
- 6) Fixings to timber must be re-tightened 2 months after installation and periodically thereafter to allow for timber shrinkage.
- 7) Substructure designer to ensure that there is no water runoff from dissimilar metals or treated timber onto barrier components.
- 8) E2 & Drainage responsibility of project engineer, to ensure that channel drainage design is not blocked or prevented to perform as designed.

OPUS VIEW SMARTLOCK™ BALUSTRADE SYSTEM SIDE FIX STEEL FIXING DETAIL

FOR RESIDENTIAL & COMMERCIAL OCCUPANCY A, A OTHER, C3, C1/C2, D, B & E OF TABLE 3.3 AS/NZS 1170.1

NOTES: Refer to design tables and elevations for post failure requirements. Interlinking rail / clips not shown for clarity.

Maximum Balustrade Heights Up to and including Extra High Wind Zone					
Residential Occupancy A, A other & C3 only		Commercial Occupancy B, E & C3 only		Commercial Occupancy C1/C2 & D	
Glass Thickness, Type	Balustrade Height (max)	Glass Thickness, Type	Balustrade Height (max)	Glass Thickness, Type	Balustrade Height (max)
12 T	1050	15 T	1200	21.52 SG	1100
13.52 SG	1050	17.2 L	1200		
15.2 L	1050	17.52 SG	1200		
		21.52 SG	1400		

General Notes:

- 1 - Glass thickness, mm
Glass type T = Toughened, L = Laminated, SG = SentryGlas
- 2 - All measurements mm
- 3 - Refer to typical Layouts for Max Panel widths and the use of Top Interlinking Rails (T & L) or Stiffener Brackets (L & SG)

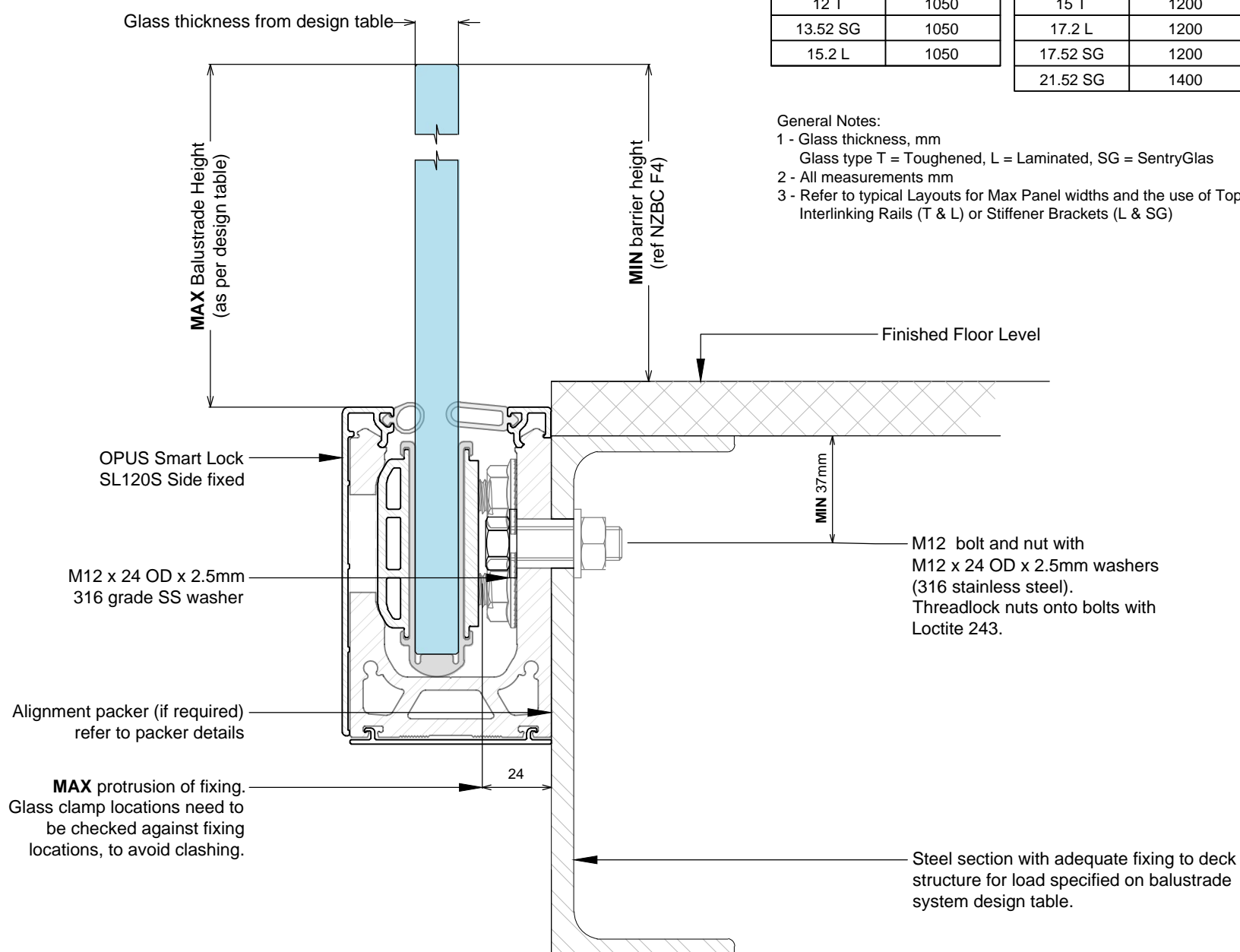

NOTES:

- 1) Capacity of structure is to be of sufficient strength to support loads M* and T* specified on balustrade system design table. Structure capacity to be verified by building engineer prior to fixing balustrade.
- 2) Max loading to comply with AS/NZS 1170.1:2002 minimum imposed actions for barriers occupancy, shown at top of drawing, for design in accordance with balustrade system design table.
- 3) For fixing to steel substrates, the installer shall ensure the bolts are tightened to a "snug-tight" level as defined in NZS3404.
- 4) No substitution allowed - any variation from the details above and design tables will require specific design.
- 5) Substructure designer to ensure that there is no water runoff from dissimilar metals or treated timber onto barrier components.
- 6) E2 & Drainage responsibility of project engineer, to ensure that channel drainage design is not blocked or prevented to perform as designed.

OPUS VIEW SMARTLOCK™ BALUSTRADE SYSTEM SIDE FIX STEEL THROUGH BOLT FIXING DETAIL

FOR RESIDENTIAL & COMMERCIAL OCCUPANCY A, A OTHER, C3, C1/C2, D, B & E OF TABLE 3.3 AS/NZS 1170.1

NOTES: Refer to design tables and elevations for post failure requirements. Interlinking rail / clips not shown for clarity.

Maximum Balustrade Heights Up to and including Extra High Wind Zone					
Residential Occupancy A, A other & C3 only		Commercial Occupancy B, E & C3 only		Commercial Occupancy C1/C2 & D	
Glass Thickness, Type	Balustrade Height (max)	Glass Thickness, Type	Balustrade Height (max)	Glass Thickness, Type	Balustrade Height (max)
12 T	1050	15 T	1200	21.52 SG	1100
13.52 SG	1050	17.2 L	1200		
15.2 L	1050	17.52 SG	1200		
		21.52 SG	1400		

General Notes:

- 1 - Glass thickness, mm
Glass type T = Toughened, L = Laminated, SG = SentryGlas
- 2 - All measurements mm
- 3 - Refer to typical Layouts for Max Panel widths and the use of Top Interlinking Rails (T & L) or Stiffener Brackets (L & SG)

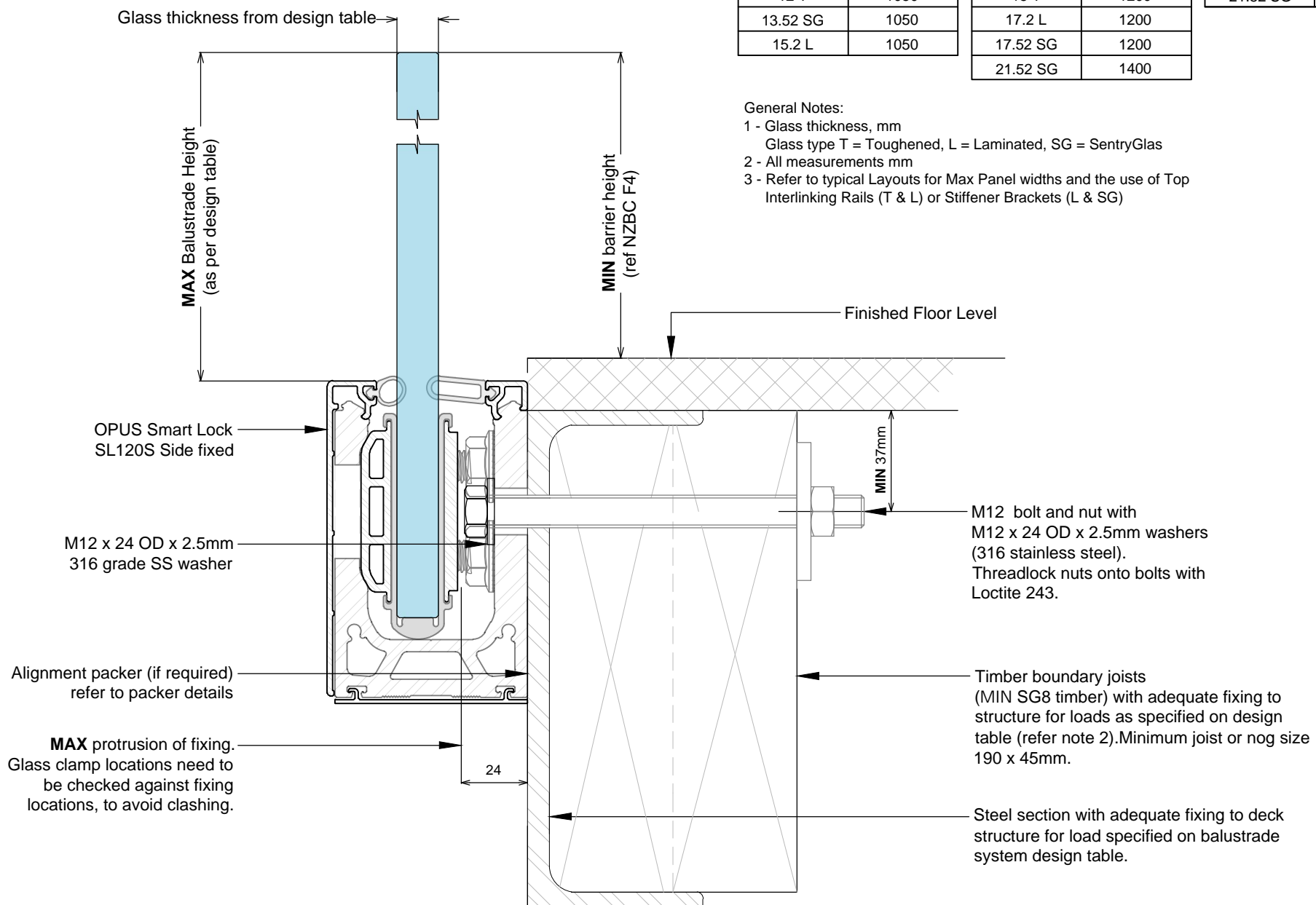

NOTES:

- 1) Capacity of structure is to be of sufficient strength to support loads M* and T* specified on balustrade system design table. Structure capacity to be verified by building engineer prior to fixing balustrade.
- 2) Max loading to comply with AS/NZS 1170.1:2002 minimum imposed actions for barriers occupancy, shown at top of drawing, for design in accordance with balustrade system design table.
- 3) For fixing to steel substrates, the installer shall ensure the bolts are tightened to a "snug-tight" level as defined in NZS3404.
- 4) No substitution allowed - any variation from the details above and design tables will require specific design.
- 5) Substructure designer to ensure that there is no water runoff from dissimilar metals or treated timber onto barrier components.
- 6) E2 & Drainage responsibility of project engineer, to ensure that channel drainage design is not blocked or prevented to perform as designed.

OPUS VIEW SMARTLOCK™ BALUSTRADE SYSTEM SIDE FIX STEEL FIXING DETAIL - SUSPENDED DECK

FOR RESIDENTIAL & COMMERCIAL OCCUPANCY A, A OTHER, C3, C1/C2, D, B & E OF TABLE 3.3 AS/NZS 1170.1

NOTES: Refer to design tables and elevations for post failure requirements. Interlinking rail / clips not shown for clarity.

THIS IS A NON STANDARD FIXING DETAIL AND MUST BE CONFIRMED BY THE PROJECT ENGINEER

Maximum Balustrade Heights Up to and including Extra High Wind Zone					
Residential Occupancy A, A other & C3 only		Commercial Occupancy B, E & C3 only		Commercial Occupancy C1/C2 & D	
Glass Thickness, Type	Balustrade Height (max)	Glass Thickness, Type	Balustrade Height (max)	Glass Thickness, Type	Balustrade Height (max)
12 T	1050	15 T	1200	21.52 SG	1100
13.52 SG	1050	17.2 L	1200		
15.2 L	1050	17.52 SG	1200		
		21.52 SG	1400		

Important Installation Notes;

- 1 - The Project Engineer must ensure the structure can support the appropriate loads
- 2- Substructure shown indicatively only
- 3- Fixings must engage into the structural slab
- 4- Use Threadlok on Nuts
- 5- All fixings must be Stainless Steel

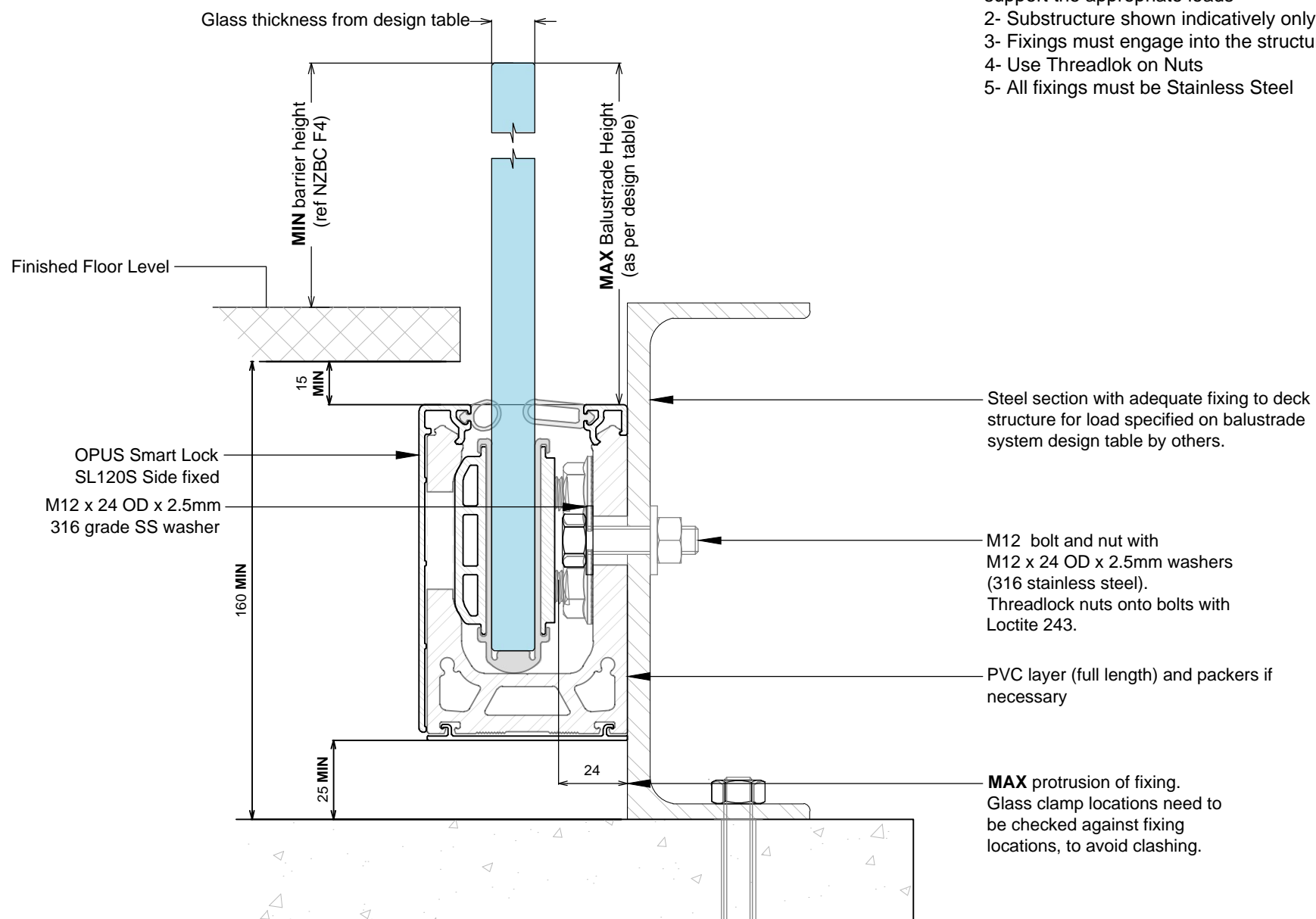

NOTES:

- 1) Capacity of structure is to be of sufficient strength to support loads M^* and T^* specified on balustrade system design table. Structure capacity to be verified by building engineer prior to fixing balustrade.
- 2) Max loading to comply with AS/NZS 1170.1:2002 minimum imposed actions for barriers occupancy, shown at top of drawing, for design in accordance with balustrade system design table.
- 3) For fixing to steel substrates, the installer shall ensure the bolts are tightened to a "snug-tight" level as defined in NZS3404.
- 4) No substitution allowed - any variation from the details above and design tables will require specific design.
- 5) Substructure designer to ensure that there is no water runoff from dissimilar metals or treated timber onto barrier components.
- 6) E2 & Drainage responsibility of project engineer, to ensure that channel drainage design is not blocked or prevented to perform as designed.

OPUS VIEW SMARTLOCK™ BALUSTRADE SYSTEM SIDE FIX CONCRETE FIXING DETAIL - SUSPENDED DECK

FOR RESIDENTIAL & COMMERCIAL OCCUPANCY A, A OTHER, C3, C1/C2, D, B & E OF TABLE 3.3 AS/NZS 1170.1

NOTES: Refer to design tables and elevations for post failure requirements. Interlinking rail / clips not shown for clarity.

THIS IS A NON STANDARD FIXING DETAIL AND MUST BE CONFIRMED BY THE PROJECT ENGINEER

Maximum Balustrade Heights Up to and including Extra High Wind Zone					
Residential Occupancy A, A other & C3 only		Commercial Occupancy B, E & C3 only		Commercial Occupancy C1/C2 & D	
Glass Thickness, Type	Balustrade Height (max)	Glass Thickness, Type	Balustrade Height (max)	Glass Thickness, Type	Balustrade Height (max)
12 T	1050	15 T	1200	21.52 SG	1100
13.52 SG	1050	17.2 L	1200		
15.2 L	1050	17.52 SG	1200		
		21.52 SG	1400		

Important Installation Notes;

- 1 - The Project Engineer must ensure the structure can support the appropriate loads
- 2- Substructure shown indicatively only
- 3- Fixings must engage into the structural slab
- 4- Use Threadlok on Nuts
- 5- All fixings must be Stainless Steel

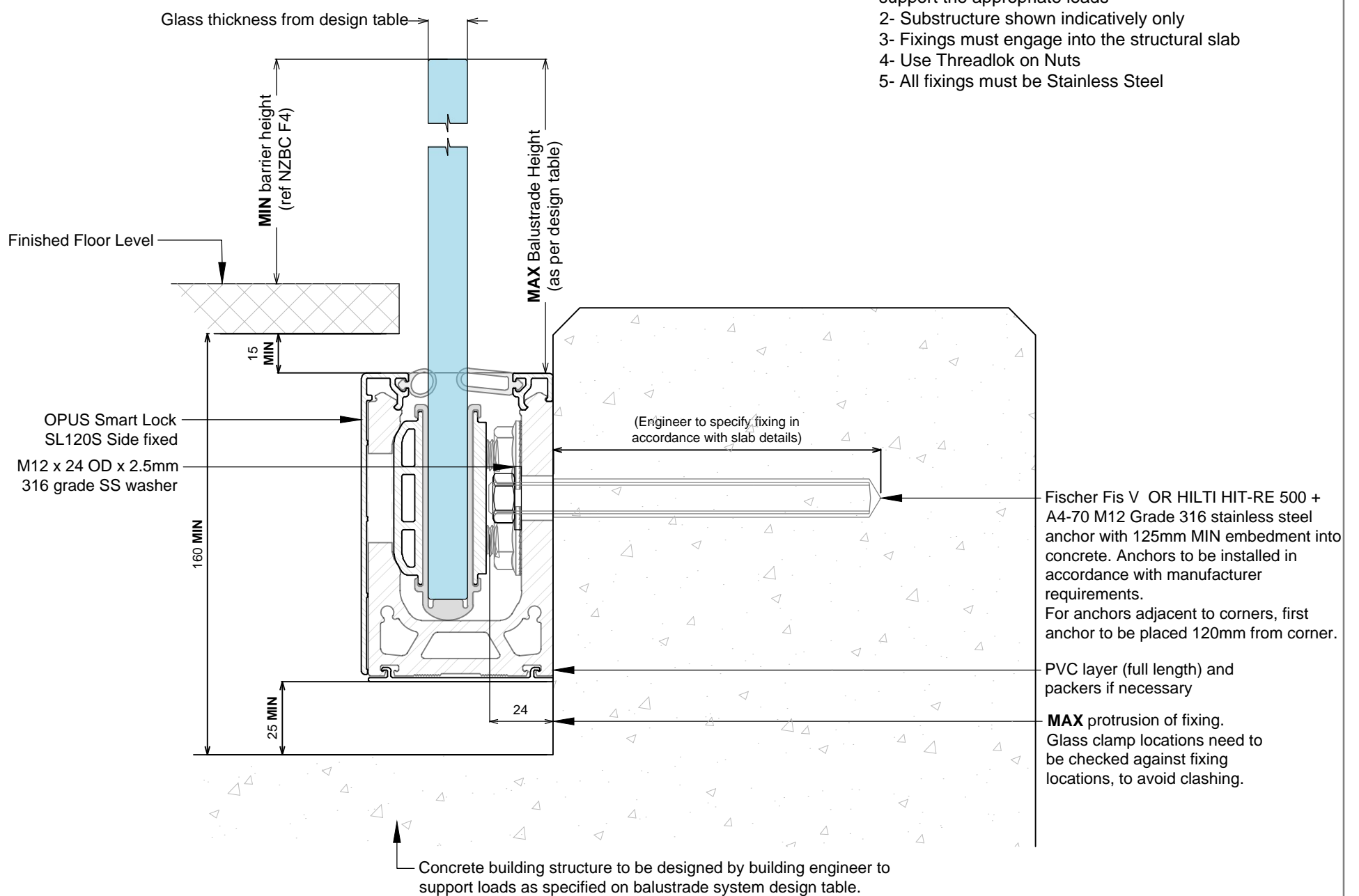

NOTES:

- 1) Capacity of structure is to be of sufficient strength to support loads M^* and T^* specified on balustrade system design table. Structure capacity to be verified by building engineer prior to fixing balustrade.
- 2) Max loading to comply with AS/NZS 1170.1:2002 Minimum Imposed Actions for Barriers Occupancy, shown at top of drawing, for design in accordance with balustrade system design table.
- 3) No substitution allowed - any variation from the details above and design tables will require specific design.
- 4) Substructure designer to ensure that there is no water runoff from dissimilar metals or treated timber onto barrier components.
- 5) E2 & Drainage responsibility of project engineer, to ensure that channel drainage design is not blocked or prevented to perform as designed.

OPUS VIEW SMARTLOCK™ BALUSTRADE SYSTEM SIDE FIX ELEVATION TYPICAL LAYOUTS

SMARTLOCK Balustrade System Side Fix + Interlinking Rail

Glass must have a minimum strength of 100MPa. All edges polished

Residential & Domestic
Occupancy types A, A Other & C3 for;

- 12mm Toughened Glass
- 15.2mm Laminated Glass
- 13.52mm SentryGlas

Refer page, 'Allowable heights for Side Fix
Balustrade' for differing Wind Zones

Use 3.5 x Clamps per m (10 per 3mtr)

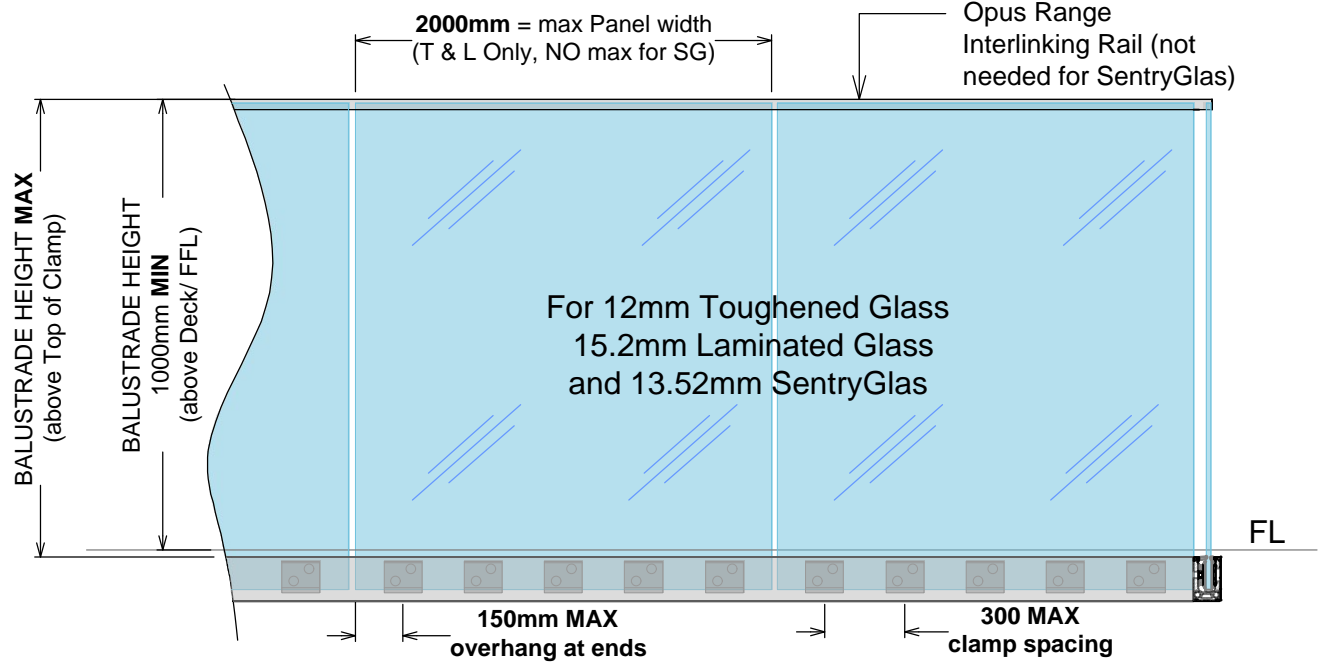

Exceeds the wind loading for all Wind Zones up to **and including** Extra High Wind Zone as set out in NZS 3604:2011

SMARTLOCK Balustrade System Side Fix + Interlinking Rail

Glass must have a minimum strength of 100MPa. All edges polished

Commercial
Occupancy types B, E & C3 for;

- 15mm Toughened Glass
- 17.2mm Laminated Glass
- 17.52mm SentryGlas

Refer page, 'Allowable heights for Side Fix
Balustrade' for differing Wind Zones

Use 3.5 x Clamps per m (10 per 3mtr)

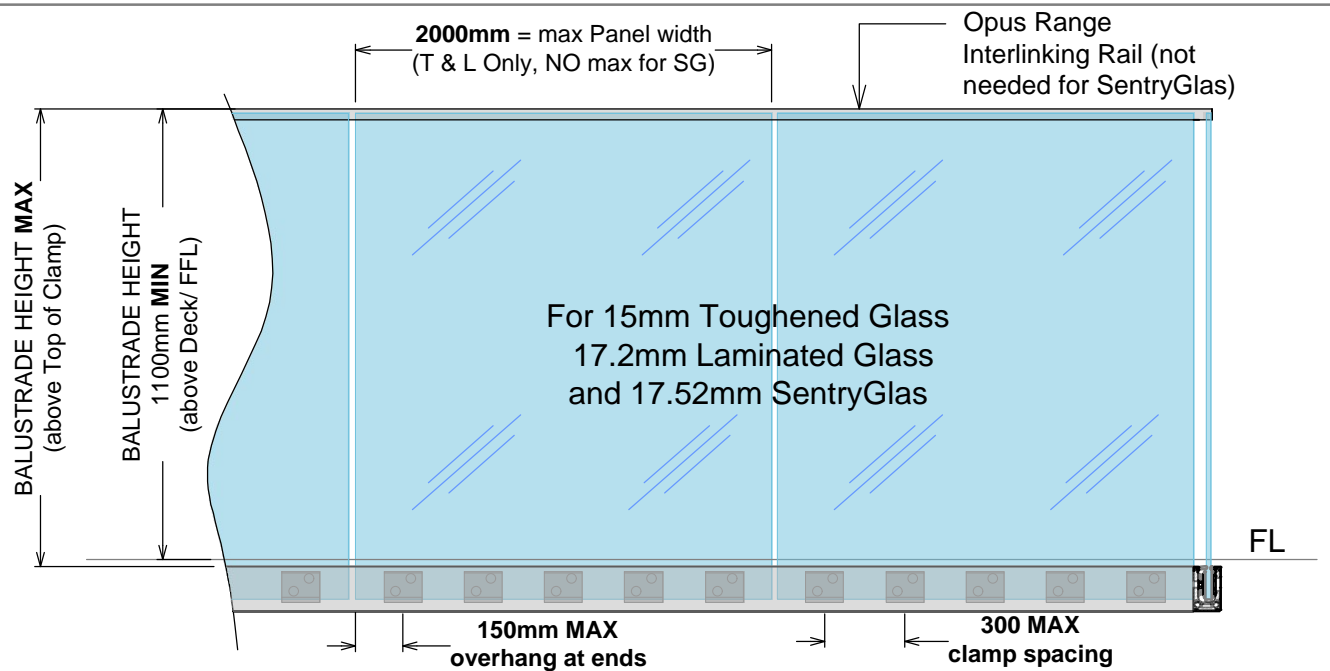

Exceeds the wind loading for all Wind Zones up to **and including** Extra High Wind Zone as set out in NZS 3604:2011

SMARTLOCK Balustrade System Side Fix

Glass must have a minimum strength of 100MPa. All edges polished

POOL FENCE only

Applies to Swimming Pools as of Jan 2017, complies with the Building Code clause F9 and seciton 162C of the building act

Applies to Pool Fences not protecting a fall of 1.0m or more

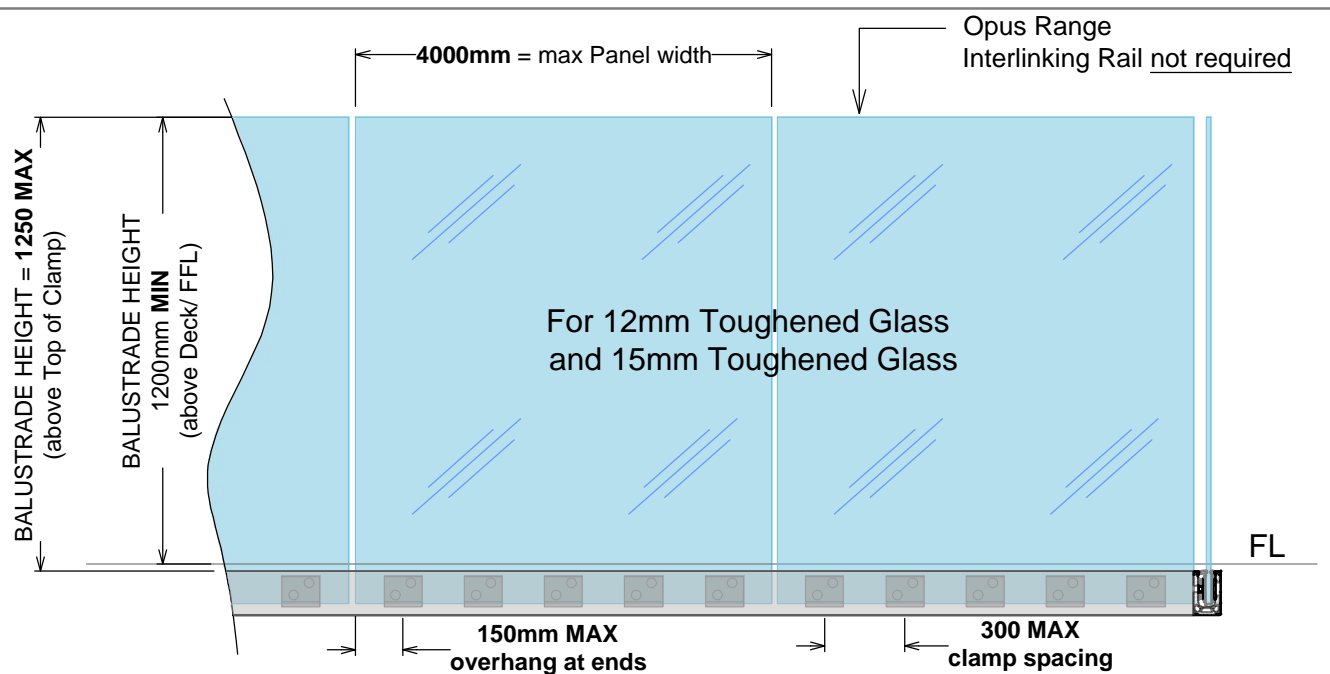

For Both Wind Zone/ Glass thickness- Barrier height = 1250mm MAX (above FFL)

12mm Toughened- up to **and including** Very High Wind Zone

15mm Toughened- up to **and including** Extra High Wind Zone

OPUS VIEW SMARTLOCK™ BALUSTRADE SYSTEM SIDE FIX ELEVATION TYPICAL LAYOUTS

SMARTLOCK Balustrade System Side Fix + Stiffener Brackets

Glass must have a minimum strength of 100MPa. All edges polished

Residential & Domestic
Occupancy types A, A Other & C3 for;

- 15.2mm Laminated Glass
- 13.52mm SentryGlas

Refer page, 'Allowable heights for Side Fix
Balustrade' for differing Wind Zones

Use 3.5 x Clamps per m (10 per 3mtr)

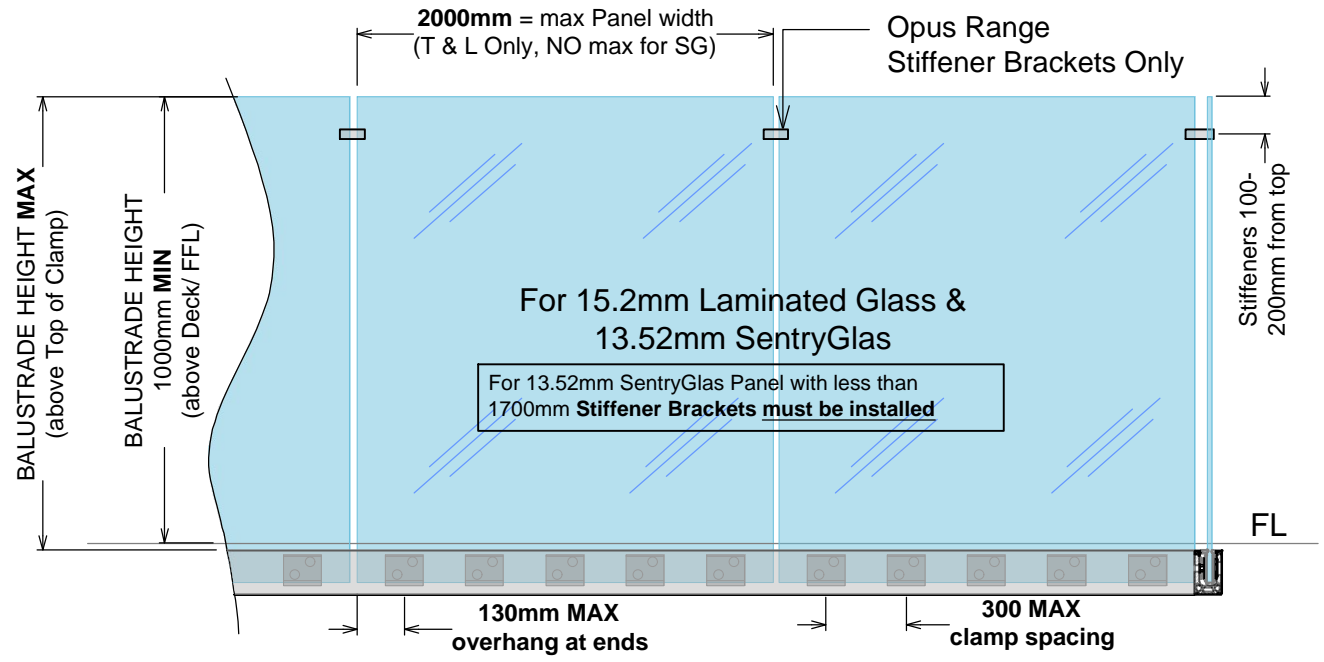

Exceeds the wind loading for all Wind Zones up to **and including** Extra High Wind Zone as set out in NZS 3604:2011

SMARTLOCK Balustrade System Side Fix + Stiffener Brackets

Glass must have a minimum strength of 100MPa. All edges polished

Commercial
Occupancy types B, E & C3 for;

- 17.2mm Laminated Glass
- 17.52mm SentryGlas

Refer page, 'Allowable heights for Side Fix
Balustrade' for differing Wind Zones

Use 3.5 x Clamps per m (10 per 3mtr)

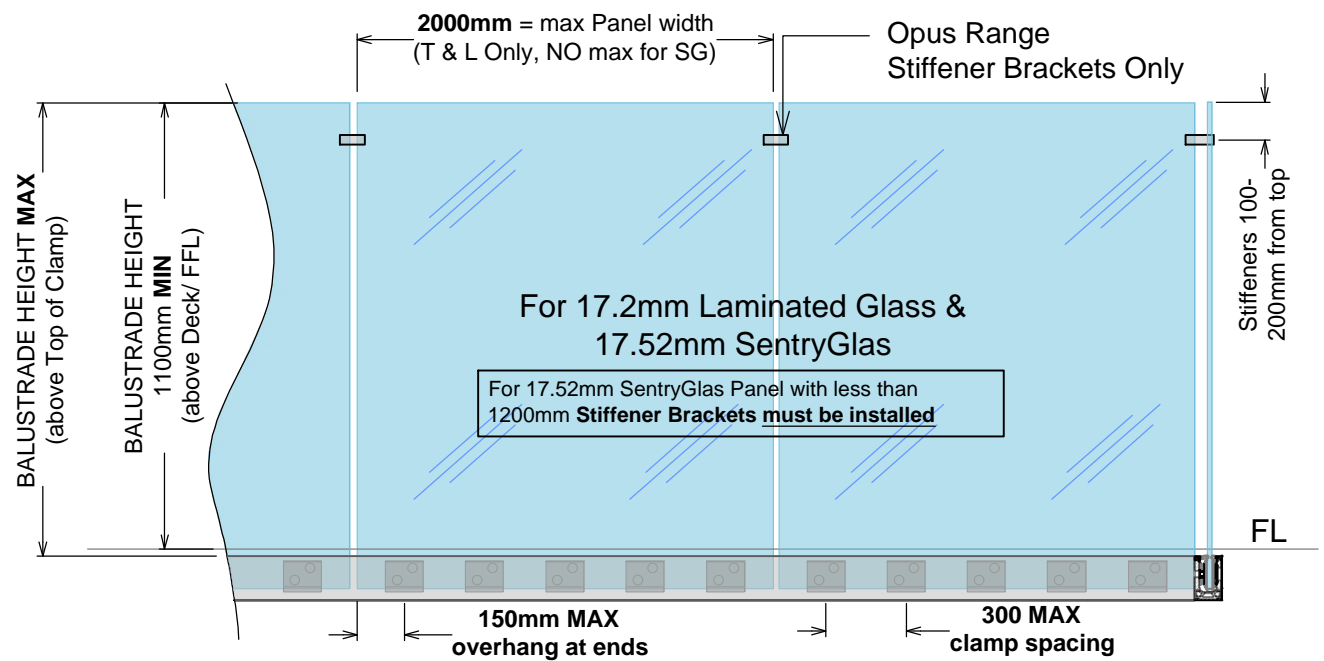

Exceeds the wind loading for all Wind Zones up to **and including** Extra High Wind Zone as set out in NZS 3604:2011

SMARTLOCK Balustrade System Side Fix + Stiffener Brackets

Glass must have a minimum strength of 100MPa. All edges polished

Commercial
Occupancy types B, E, C1/C2 & C3 for;

- 21.52mm SentryGlas

Refer page, 'Allowable heights for Side Fix
Balustrade' for differing Wind Zones

Use 3.5 x Clamps per m (10 per 3mtr)

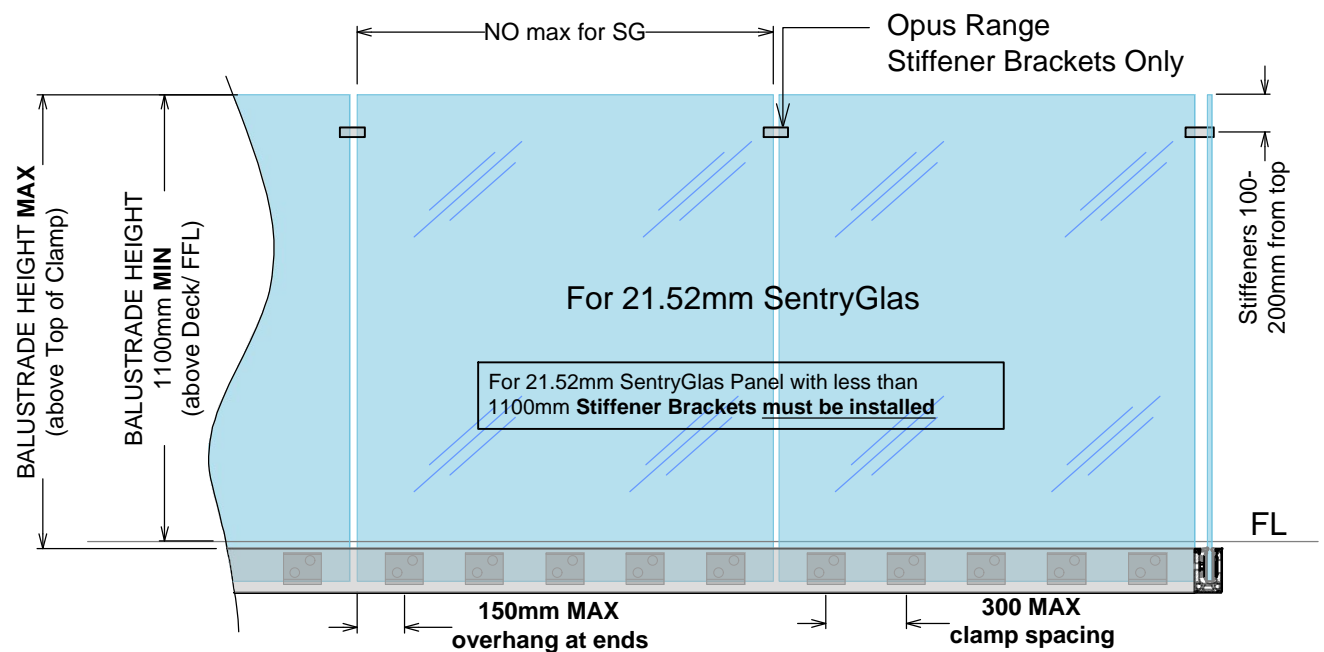

Exceeds the wind loading for all Wind Zones up to **and including** Extra High Wind Zone as set out in NZS 3604:2011

OPUS VIEW SMARTLOCK™ BALUSTRADE SYSTEM SIDE FIX TYPICAL STAIR SETOUT

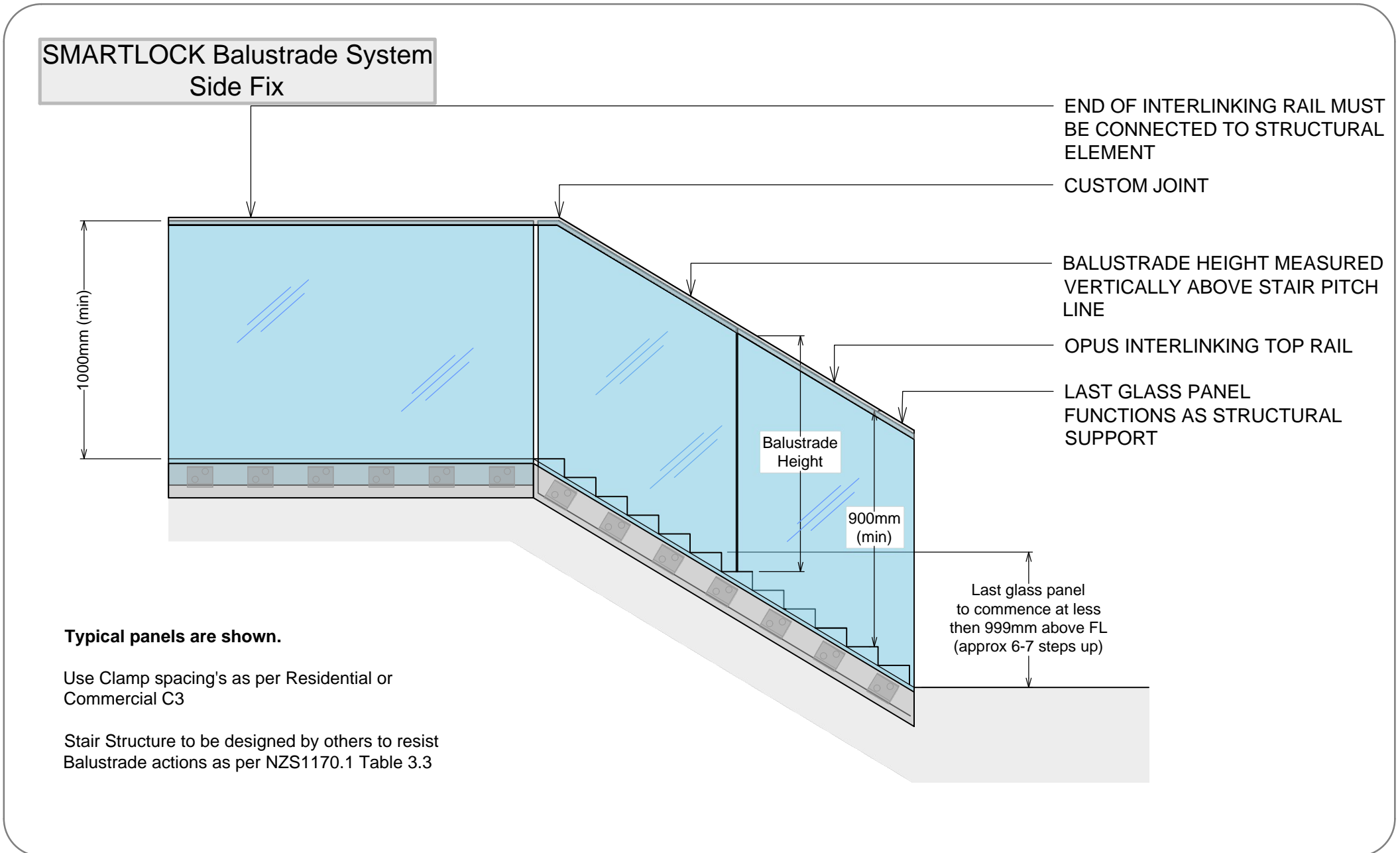

SMARTLOCK Balustrade System Side Fix Packer Detail

SMARTLOCK Balustrade System Side Fix Only Stairs Stringer Detail

Stair structure to be designed by others to resist Balustrade actions as per NZS1170.1 Table 3.3
For Internal Use Only Residential Type A

